

**LED Vapor Tight - Watt and CCT Selectable**



**Application:** Parking garages, shopping centers, car washes, and many other commercial or industrial applications

**FEATURE**

- Wet location rated with IP66 ingress protection rating. Suitable for damp location
- Watt and CCT adjustable to fit for different locations
- Long life hours with a durable housing
- 1-10V dimmable: Light can be dimmed to ideal brightness levels to save energy and get the light levels correct for your area.
- With option of build-in motion sensor or emergency backup driver

**ACCESSORIES**



- Plastic Anchors
- Screw for anchor
- Strain Relief Connectors
- Mounting brackets (2 for 2FT/4FT and 3 for 8FT)

**ORDERING GUIDE**

Model		RY-4FT-VT-H-3W3CCT	RY-8FT-VT-H-3W3CCT
Power		20/30/40W Selectable	40/60/80W Selectable
Size		4FT	8FT
Lumens		5200 lm @ 40W	10400 lm @ 80W
Cover		Clear Ribbed	
Input Voltage		120-277 VAC	
Dimming		Triac Dimming (10%-100%)	
Protecting Rating		IP66	
Power Factor		0.9+	
Beam Angle		120°	
CCT		3000K/4000K/5000K Selectable	
CRI		80+	
Surge protection DM/CM		1.25 kV / 1.25 kV	
Working Life		Lumen Maintenance over 70% @50,000+ hours	
Oper. Temperature		- 13°F ~+113°F / -25°C ~+45°C	
Housing		Polycarbonate housing (PC) + Stainless Steel Clips	
Option (XX)		XX can be: MS: Microwave Motion Sensor EM: Emergency Backup Driver	

**LED Vapor Tight - Watt and CCT Selectable**

**DIMENSION**

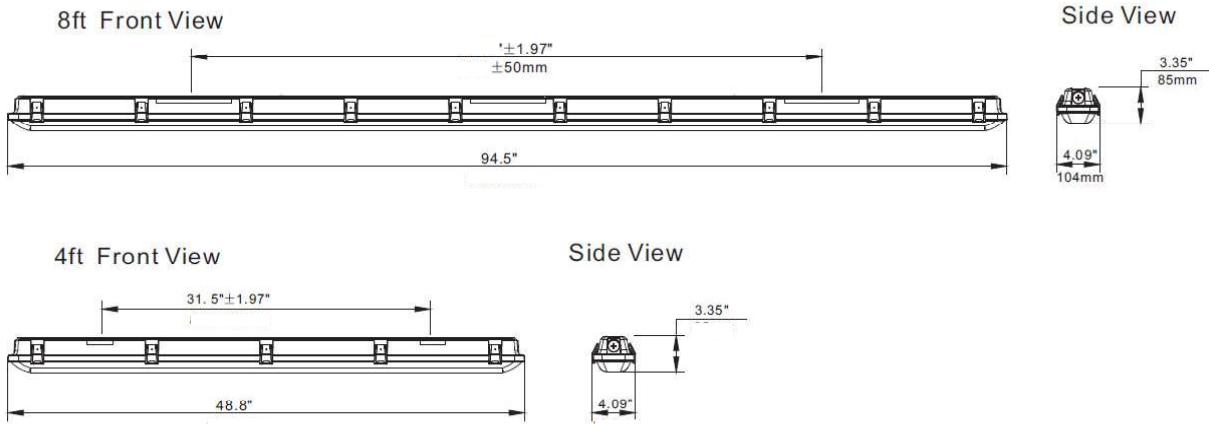

**PACKAGE INFO**

Model. No.		RY-4FT-VT-H-3W3CCT	RY-8FT-VT-H-3W3CCT
Size		4FT	8FT
QTY/PACK		6PCS/PACK	4PCS/Pack
Package Size		1290X245X280mm 50.8"X9.65"X11.02"	96.5"X9.65"X7.87"
Package Weight		15.1 kg/33.29 lbs	24 kg/52.91 lbs
Package CBM		0.088494	0.12005
40GP Capacity		~3930PCS	~1930PCS
40HQ Capacity		~4610PCS	~2260PCS
45HQ Capacity		~5280PCS	~2590PCS

**PHOTOMETRIC REPORT**

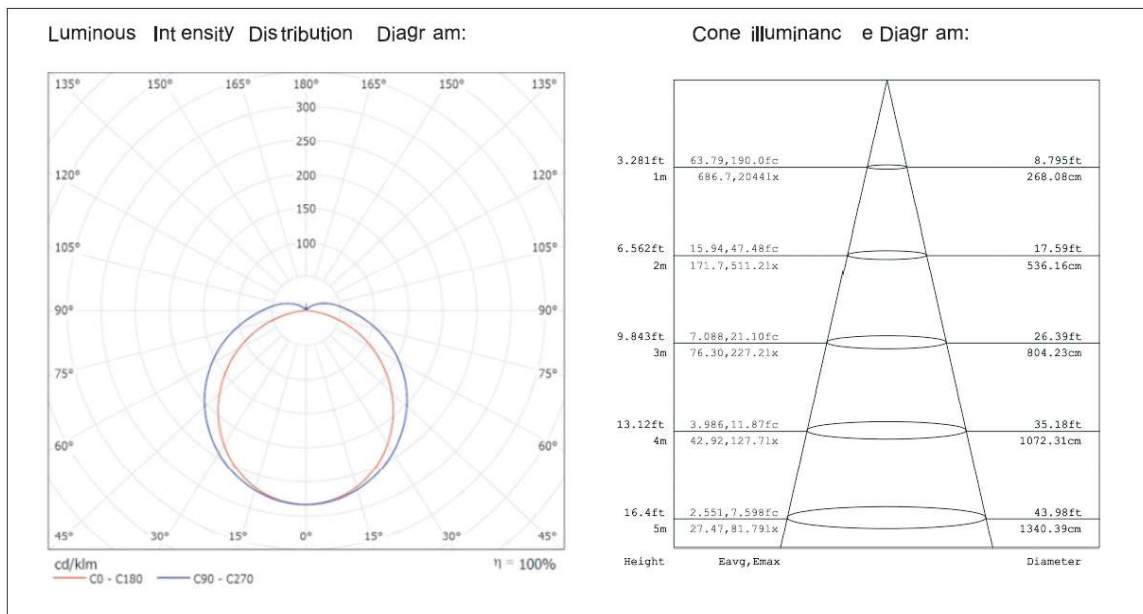

## LED Vapor Tight - Watt and CCT Selectable

### Watt and CCT Selectable

#### Surface Mount Installation

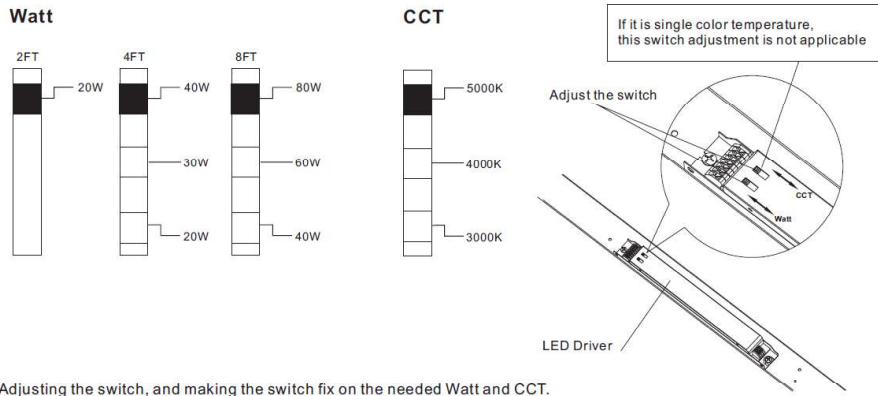

Adjusting the switch, and making the switch fix on the needed Watt and CCT.  
 Note:  
 Due to different LED driver models,  
 The specific functions of the switch are subject to the actual switch label of the LED driver supply

#### Installation

<p><b>1</b> Take down the quick end cap anticlockwise.</p>	<p><b>2</b> Fasten the waterproof connector clockwise.</p>
<p><b>Cable Model:</b>                  C(UL) SJT 5/C 18AWG(0.824mm<sup>2</sup>) 105°C 300V FT1</p> <p><b>3</b> Insert the cable through waterproof connector and wire it into terminal block. Make sure L, N, grounding and dimming wire are wired to correct holes.</p>	<p><b>4</b> Connect the male plug extended from back of reflector to the female plug from the driver.</p>
<p><b>5</b> Close the lamp diffuser, which was integrated with reflector, and lamp base, then fasten the clips which were offered in accessories bag.</p>	<p>• Connection mode</p> <p style="text-align: center;">Dimming function</p>

## LED Vapor Tight - Watt and CCT Selectable

### Build-In Motion Sensor Information

#### BUILT-IN MOTION SENSOR INFORMATION

ANT-3A

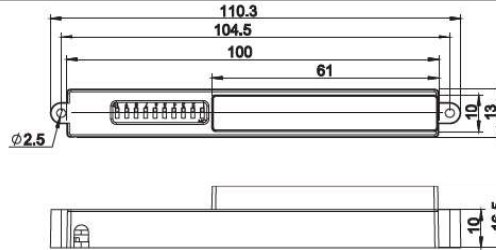
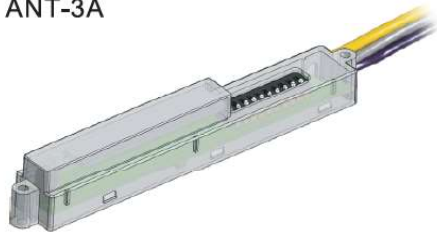

#### ⚠ WARNING

NOTE: Warm up time is 15seconds. After the sensor connects input power first time, the light will keep on 15 seconds, then go to dimming to work normally.  
 NOTE: Factory Default Setting: 100% sensitivity, Hold on time: 10seconds, Daylight sensor is 30lux, Dimming level:30%, Dimming time: 60minuties.  
 NOTE: Any setting changed by DIP Switch or remote control, the led light that sensor connect will on/off as confirm.

#### SPECIFICATIONS

Power supply	12V-24V DC, >50mA
HF System	5.8GHz±75MHz
Dim control output	0-10V, max. 25mA sinking current
Detection radius/angle	Max 17ft.(5.2m)/360°
Mounting height	Max 13ft(4m)
Remote range	50ft. (15m) Indoor, no backlight
Humidity	Max. 95% RH
Temperature	-40°F ~ 158°F (-40°C ~ 70°C)

#### PARAMETER SETTING BY DIP SWITCH

Consider the picture: 1, 2 set sensitivity; 3, 4 set hold time; 5, 6 set the lux; 7, 8 stand-by light level 9, 10 set stand-by time;

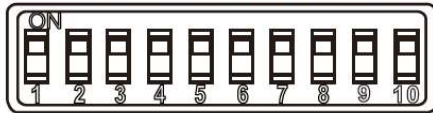

For detailed adjustment methods, please refer to the ANT-3A instruction manual

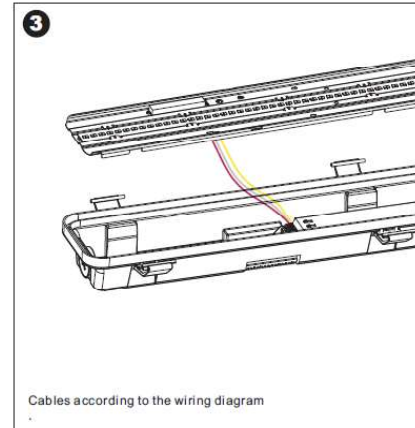
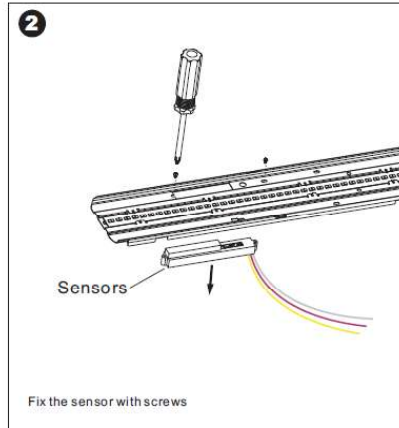
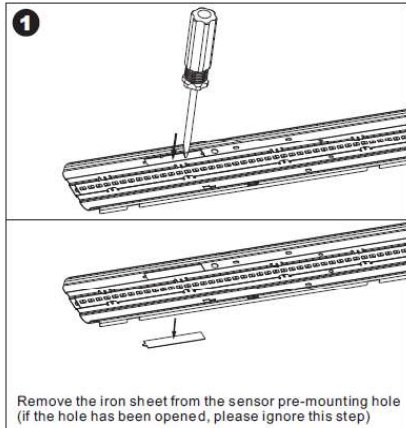
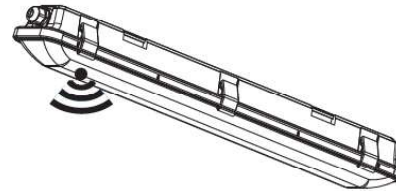

#### WIRING DIAGRAMS

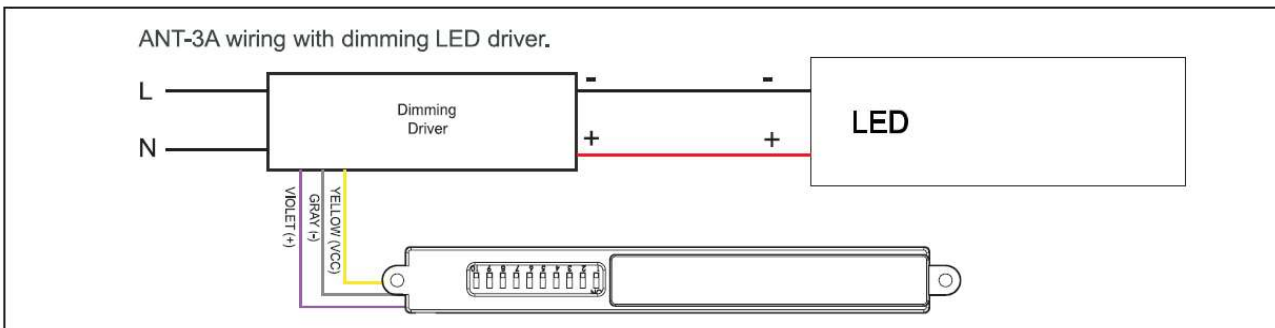



## LED Vapor Tight - Watt and CCT Selectable

### Build-In Emergency Information

#### EMERGENCY LED DRIVER INFORMATION

Specifications:



Specifications:

<b>Universal Input Voltage</b>	100-277Vac 50/60Hz
<b>AC Input Current</b>	100mA max.
<b>AC Input Power Rating</b>	7.0W max.
<b>Output Current and Voltage</b>	160-320mA 25-48Vdc
<b>Output Power</b>	8W
<b>Emergency Time</b>	≥1.5H
<b>Full Warranty</b>	5 Years
<b>Test Switch Indicator Light</b>	Illuminated Test Switch, indicator Light
<b>Battery</b>	Li-ion battery-7.4V/2500mAH
<b>Battery Charging Current</b>	250mA
<b>Charging Time</b>	≥24Hours
<b>Temperature Rating (Ambient)</b>	Li-ion 0°C to +40°C (32°F to 104°F)

#### WIRING DIAGRAM

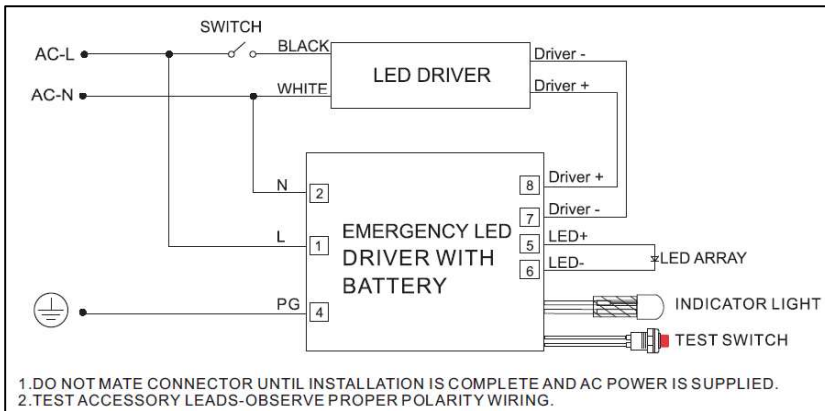

#### INSTALLATION

**1**

Emergency led driver and Battery installation position

**2**

Test Switch installation position

**3**

LED Driver

Assemble according to this drawing and wire according to the wiring diagram to complete the installation